

NLG75

Dehumidifying dryer + Loader Combination Model

● Capacity

Power		3 phases 200V 60 Hz	3 phases 220V 60 Hz	3 phases 200V 50 Hz
Temperature range		60 to 150 °C		
Dryer blower	Output	0.20 kW		
Heater	Electrical capacity	4.50 kW	5.45 kW	4.50 kW
Loader blower	Output	1.75 kW	1.75 kW	1.50 kW
Carry performance *1		410 kg/h		

*1 It is the value which used of bulk specific gravity 0.65 g/cm³ virgin material for level 9 m and perpendicular 3 m and Ø38 mm hose piping, and was measured in our company.

And this value is the case where a supply place is a vacuum cyclone PS1. (at 60 Hz)

● Standard specifications

Capacity *2		180 L / 75 kg		
Body ("Dual Package")		Heat insulated double structure		
		Side open type		
Drying system		Semi-closed circuit		
Drying media *3		Dehumidifying air (-40°C DP)		
Filter		Circulation filter		
		Exhaust filter		
Temp control	Setting / Display	Digital setting / Digital display		
	Control method	PID		
	Sensor *4	Thermocouple (J)		
Start timer *5		Subtractive type start timer 000 h : 01 m ~ 500 h : 59 m		
Purge unit	Structure	Push-damper type		
Material outlet port	Bore	1 X Ø38 mm (with coupler)		
	Secondary air port	Shutter type		
Material discharge port	Size	Ø60.5 mm		
	Structure	Manual shutter (Ø50 mm)		
Dust collection system	Main body	Dust filter box		
	Filter	Dust filter		
Material switch supplying	Main body	Air selector		
	Connection port	2 X Ø38 mm		
Safety device	Error contents	Safety device	Error notification mode	
	Earth leakage	Earth leakage circuit breaker (with overload protector)	Power OFF	
	Emergency stop	Emergency stop button Safety switch for hopper closure	Panel display + Operation stop Panel display + Operation stop	
	Sensor breakage	Control panel	Panel display + Buzzer + Operation stop	
	Reversed phase	Control panel	Panel display + Buzzer + Operation stop	
	Dryer blower overload	Overload relay	Panel display + Buzzer + Operation stop	
	Loader blower overload	Overload relay	Panel display + Buzzer + Operation stop	
	Overheat	Overheat protector	Panel display + Buzzer + Operation stop	
	Temp. High	Control panel (with standby function)	Panel display + Buzzer	
	Temp. Low	Control panel (with standby function)	Panel display + Buzzer	
	Clean filter	Control panel	Panel display + Buzzer	
	Power failure *5	Control panel	Panel display	
	Colour *6	A45-90A (Gloss)		

*2 The value is for manual feeding.

*3 Consult us if the dew point of primary air under atmospheric pressure exceeds -10°C.
(The dew-point temperature is that of dehumidifying air.)

*4 Sensor(s) may change by customer's demand.

*5 To prevent accident, the machine stops upon a power failure during the operation and does not restart automatically after power restoration.
If a power failure occurs after the timer has been set, the timer-start is canceled.

*6 The colour (paint colour) may be changed according to the customer's request.

NLG75

Dehumidifying dryer + Loader Combination Model

● Accessories

Power cord	5 m
Hose	Ø38 mm x 20 m (L) (without earth wire)
Hose band	6 pieces for Ø38 mm hose

● Utilities

Power		3 phases 200V 60 Hz	3 phases 220V 60 Hz	3 phases 200V 50 Hz
Electric capacity		6.45 kW	7.40 kW	6.20 kW
Rated current		21.6 A	22.5 A	19.9 A
Circuit breaker capacity		30 A		
Air	Quantity	12.5 Nm ³ /h		
	Pressure	0.45 MPa		
Size *7		W923 X D551 X H2249 (mm)		
Weight *8		285 kg		

*7 Protrusions are not contained.

*8 Weight of a standard model

● Flow

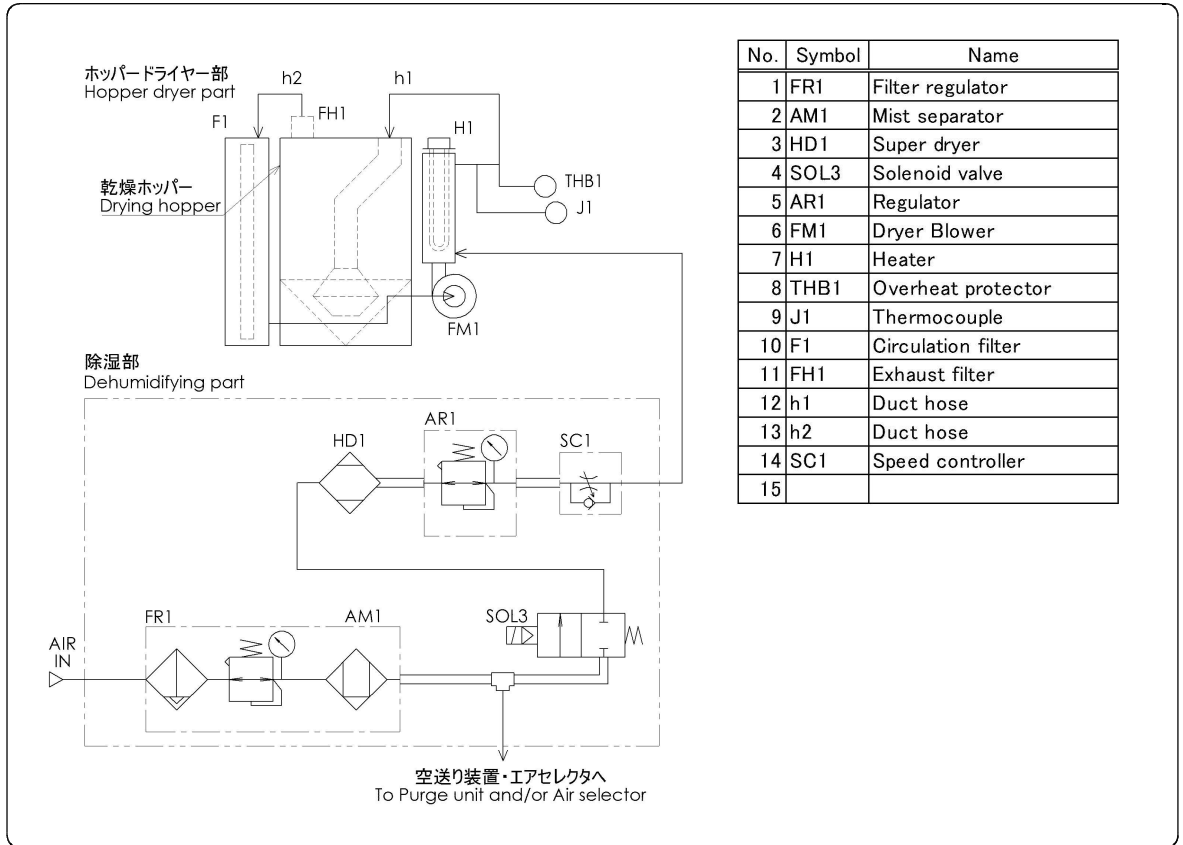

□ Specification may be changed without prior notice.

NLG75

Dehumidifying dryer + Loader Combination Model

● Outline view

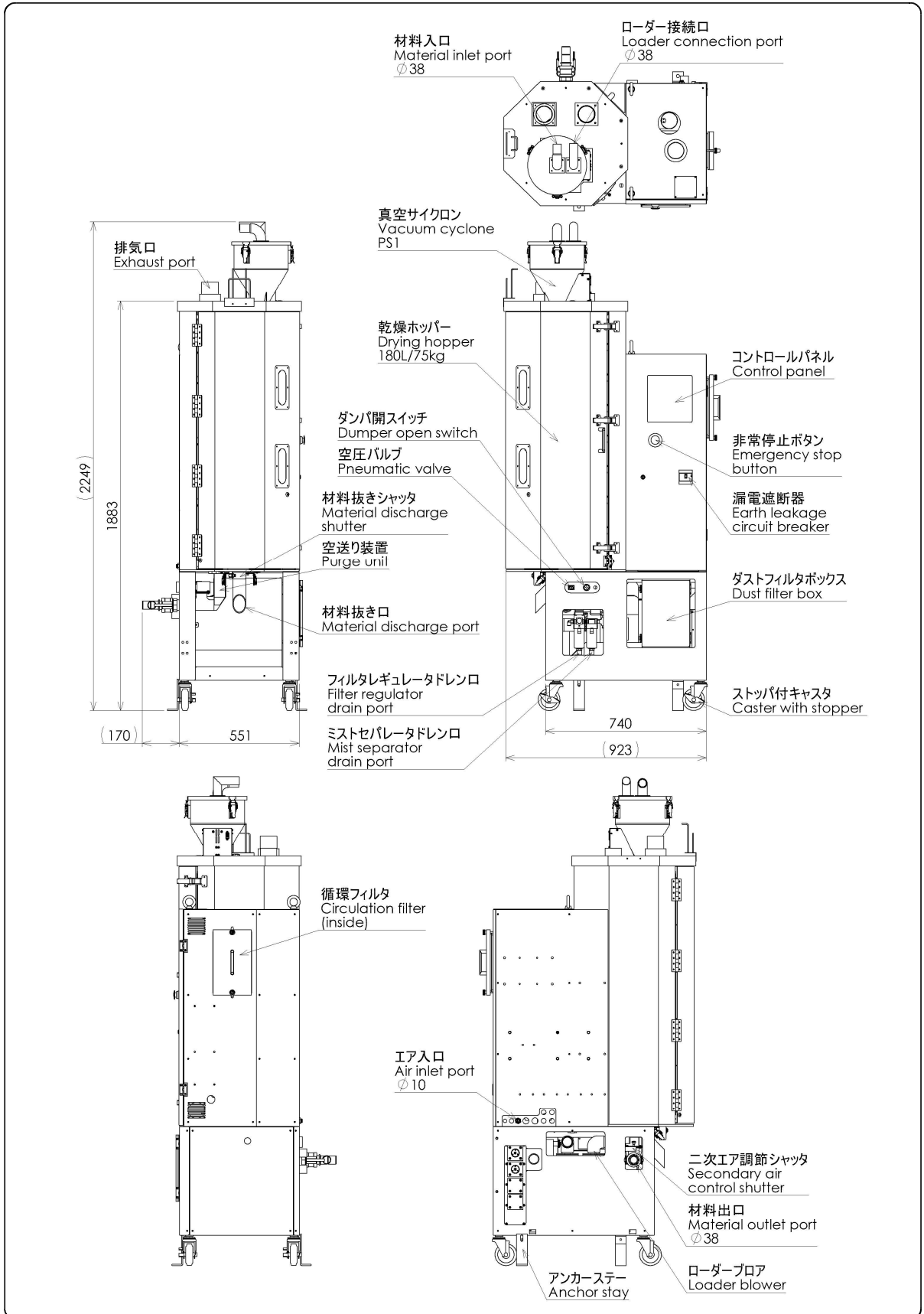

□ Specification may be changed without prior notice.

